

**INNOVATION  
2018**

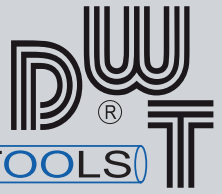

Made in Europe



„THE NEW GENERATION“

**exact**  
PRO SERIES PIPECUT 360



LED-INDICATION

	OK
	Slow down
	Motor temperature critical, motor protection active

- ✓ More powerful motor
- ✓ Integrated laser for an exact alignment of the blade
- ✓ Visual indication of the ideal cutting speed
- ✓ Motor overload protection

WEIGHT



11,7  
kg

RANGE OF USE



70 mm - 360 mm

MAX PIPE WALL

STEEL  
20 mm

PLASTIC  
45 mm

SUITABLE FOR

**ALL**  
Materials



[www.dwt-gmbh.de](http://www.dwt-gmbh.de)

# NEW PipeCut 360 PRO SERIES

## PROFESSIONAL PIPE CUTTING TOOLS FOR DEMANDING CONDITIONS

### PipeCut 360 Pro Series ADVANTAGES

- ☑ Extremely safe to use
- ☑ Easy to use
- ☑ Powerful and durable
- ☑ Overload indicator for an optimal cutting speed
- ☑ Laser indicator for an exact alignment for the blade
- ☑ Easy to transport

### PipeCut 360 Pro Series

**Voltage/Power/Current** 220-240 V | 2500 W | 12 A

**Ø Blade diameter** 165 mm

**Range of use** 70 mm - 360 mm

#### Pipe material

Suitable for all pipe materials such as steel, plastic (PE, PP, PVC, etc.), stainless steel, copper, aluminum and cast iron.

- ⇒ TCT 165, for steel, copper and plastic pipes
- ⇒ Diamant X 165 Cutting Disc, for cast iron pipes
- ⇒ ALU 165, for all plastic and aluminum pipes
- ⇒ Cermet 165, for steel and stainless steel pipes

### OPTICAL indication of the ideal cutting speed to protect the motor and the saw blades

LED INDICATE	OVER HEATING SITUATION	TEXT ON THE STICKER ON SIDE OF LIGHT
Green (steady)	Motor temperature low, full power available.	GO AHEAD
Yellow blinking	Motor temperature high, but not critical yet, full power available.	SLOWER THE FEED SPEED
Red blinking	Motor temperature critical, motor protection active with slow running, fully unload the cutting blades to let the motor cool down while slowly running.  <b>OVER CURRENT SITUATION</b> Over current situation has realized. Motor protection active with slow running, fully unload the cutting blades to let the motor cool down while slowly running.	LET THE MOTOR RUN UNTIL GREEN LIGHT IS ON

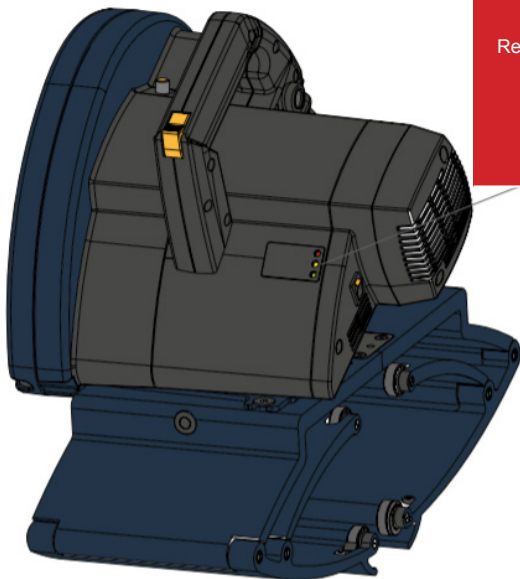

**exact**  
PRO SERIES PIPECUT 360

**DW**  
PIPE TOOLS