

Special equipment for DLW

Pipe cold cutting machine

- Inside counterbore
- Flange facing
- Outside turning module
- Spring load holder
- Deck Cutter

Inside Counterbore

DLW-CB:

Internal beveling device for calibration of inside diameter and inside boring of max. 200 mm depth (CB1: 200 mm, CB2: 90 mm depth), adjustable 0° - 25°.



Video of application

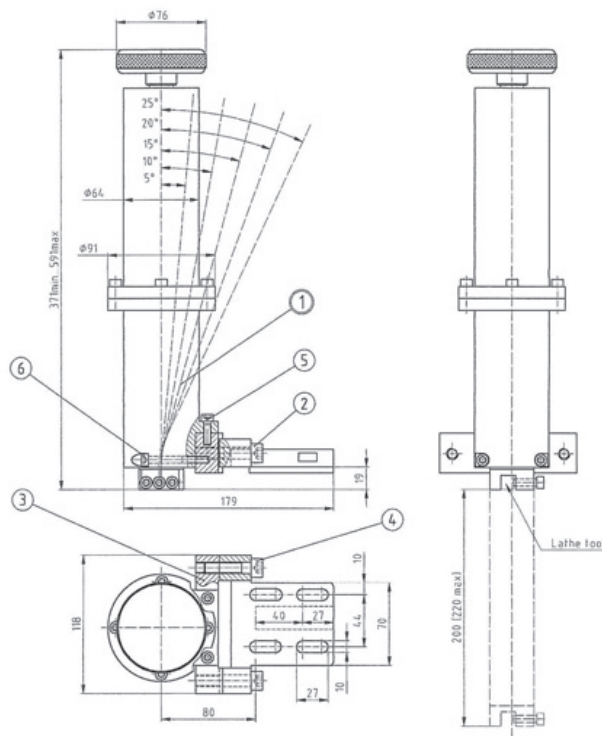

Flange Facing

DLW-FF:

Flange facing device for DLW machines to regroove the flange surface, automatic feed mechanism to be used together with DLW-CB. Suitable for DLW 5-10 up to max. DLW 30-36.



Video of application

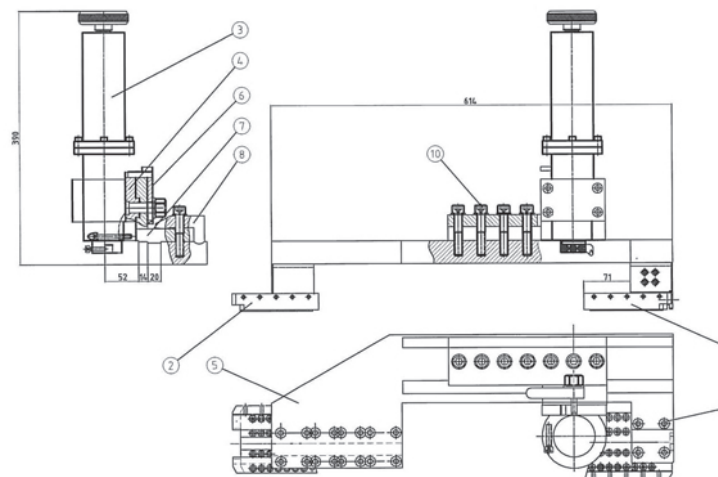

*Picture shows DLW-FF incl. DLW-CB

Outside turning module

DLW-ETM

The external turning module DLW-ETM can be used for external machining of heavy wall steel pipes. External insulation of pipelines as well as overlapping weld seams can be removed.

Travel: 188mm

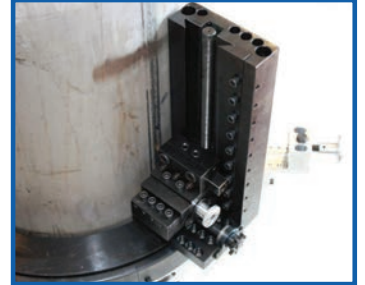
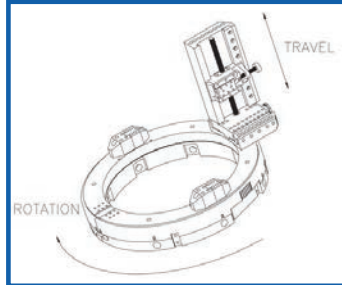

Spring Load Holder

DLW-SLH

The spring load holder DLW-SLH is used for pipe cold cutting and fast beveling of out-of-round pipes. The spring load holder provides a perfect beveling result for this application.

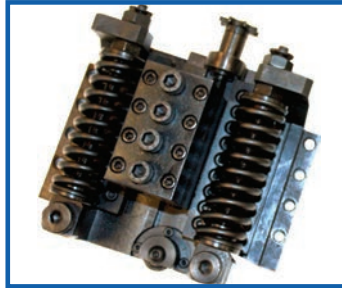

Deck Cutter

Application:

By using strong magnets and a special tool holder all DLW machines from 12 – 48 " can be converted to a deck cutter. This is a portable machine which is able to cut big holes in heavy wall plates.

